



firefly 

Model: FF550

OPERATING MANUAL



DO-ALL OUTDOORS, LLC.
1207 16th Avenue, South • Nashville, TN 37212, USA
Customer Service: 1-866-SHOT-DOC
www.doalloutdoors.com

**WARNING: TO AVOID SERIOUS INJURY, PLEASE
READ AND FOLLOW ALL INSTRUCTIONS**



FOR QUESTIONS REGARDING THE FIREFLY PLEASE CALL OUR CUSTOMER SERVICE DEPARTMENT AT (800-663-3712) OR VISIT OUR WEBSITE WWW.DOALLOUTDOORS.COM FOR ADDITIONAL INFORMATION AND VIDEOS. THANK YOU FOR YOUR BUSINESS!

COMPONENTS:

FF550

- MAIN UNIT
- 2 - FRONT LEGS
- 2 - FRONT LEG BRACKETS
- 4 - ALLEN SCREWS FOR FRONT LEGS (5/32" ALLEN WRENCH)
- 2 - FRONT SAFETY RING BRACKETS
- 2 - REAR SAFETY RING BRACKETS
- 1 - SAFETY RING
- 1 - REAR BASE
- 1 - HORSESHOE FOR STACKER POLES
- 4 - STACKER POLES
- 4 - BOLTS FOR HORSESHOE (11MM WRENCH)
- 1 - SPRING
- 1 - SPRING BOLT
- 1 - SPRING BOLT KNOB

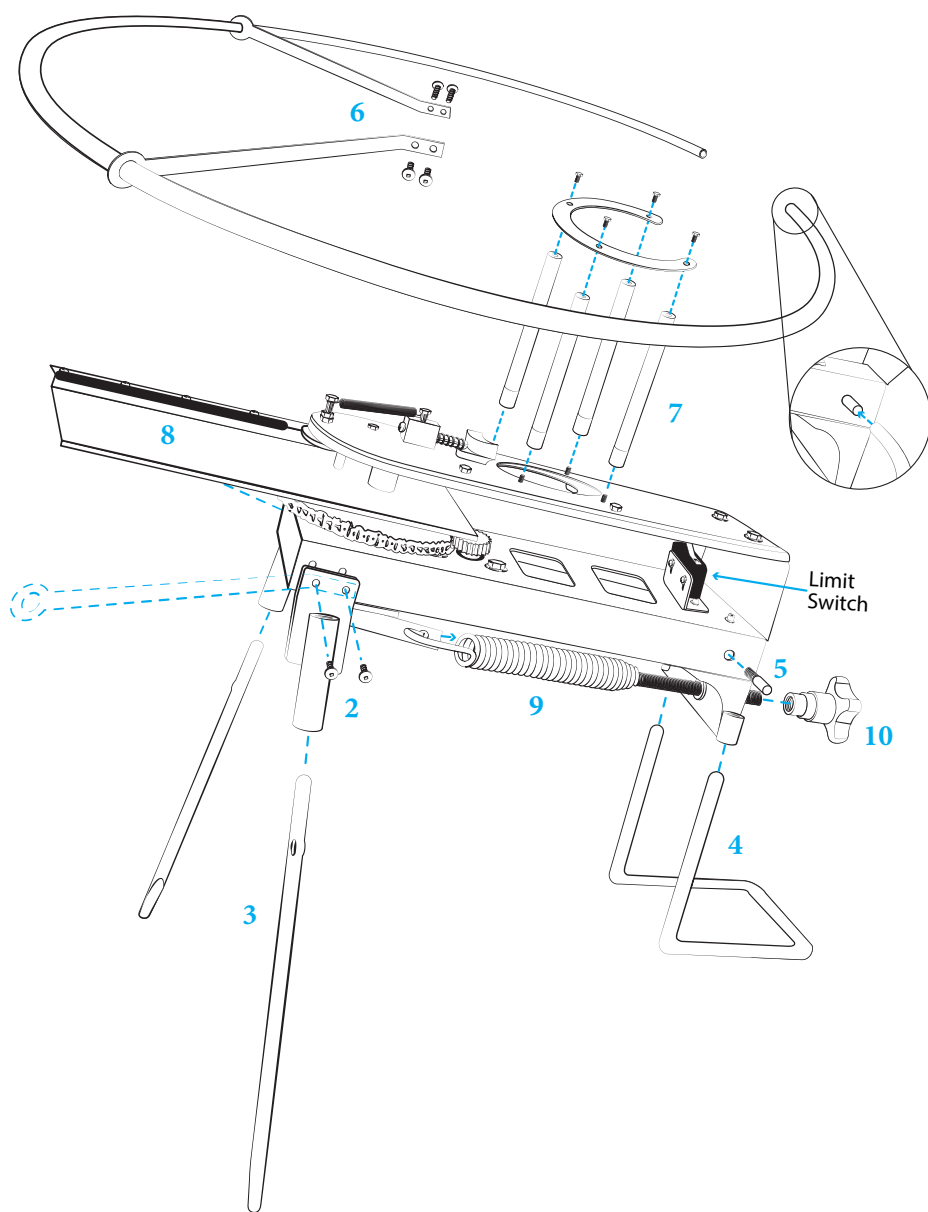

ASSEMBLY

- 1) REMOVE UNIT FROM BOX
- 2) INSTALL THE TWO FRONT LEG BRACKETS AND THE TWO FRONT SAFETY RING BRACKETS.
- 3) INSERT THE TWO FRONT LEGS INTO BRACKETS
- 4) INSTALL REAR BASE
- 5) INSTALL THE TWO SAFETY RING BRACKETS AT THE REAR OF UNIT
- 6) INSTALL SAFETY RING
- 7) INSTALL THE FOUR STACKER POLES AND HORSESHOE
- 8) MOVE ARM INTO THE TWELVE O'CLOCK POSITION (POINTING AWAY FROM UNIT)
- 9) INSTALL SPRING AND SPRING BOLT. INSERT THE SPRING BOLT INTO THE SPRING. THEN CONNECT THE SPRING TO THE EYELET UNDERNEATH THE UNIT. RUN THE SPRING BOLT THROUGH THE HOLE IN THE REAR OF THE UNIT.
- 10) INSTALL SPRING BOLT NUT. DO NOT APPLY TOO MUCH TENSION.
- 11) UNIT IS NOW READY FOR OPERATION
- 12) YOU CAN FIND SUPPORTING VIDEOS FOR THE FIRE FLY ONLINE AT WWW.DOALLOUTDOORS.COM

OPERATION

- MAKE SURE UNIT IS POINTED IN A SAFE DIRECTION
- PUSH FRONT LEGS FIRMLY INTO GROUND. DO NOT APPLY PRESSURE TO THE TOP OF UNIT
- LOAD CLAYS
- CONNECT CABLES TO 12V MARINE BATTERY (RED TO POSITIVE AND BLACK TO NEGATIVE)
- SWITCH MACHINE TO THE ON POSITION
- THE ARM WILL SLOWLY SWING AROUND AND PICK UP A CLAY AND STOP.
- FIRE BY DEPRESSING THE FOOT PEDAL. KEEP PRESSURE ON THE FOOT PEDAL UNTIL CLAY IS LAUNCHED. NEVER KEEP CONSTANT PRESSURE ON THE FOOT PEDAL. ALWAYS TAKE OFF YOUR FOOT OF THE PEDAL BETWEEN LAUNCHES.
- WHEN FINISHED SHOOTING, TURN MACHINE OFF AND DISCONNECT FROM BATTERY.
- WHEN NOT IN USE, TURN UNIT OFF. DISCONNECT UNIT FROM BATTERY. RELEASE TENSION FROM SPRING BY LOOSENING SPRING BOLT NUT. YOU MAY CHOOSE TO REMOVE SPRING COMPLETELY.
- ALWAYS REMOVE THE SPRING AND DISCONNECT UNIT FROM THE BATTERY WHEN MAKING ADJUSTMENTS.
- YOU CAN ADJUST THROWING DISTANCES BY LOOSENING OR TIGHTENING THE SPRING. NEVER OVERTIGHTEN SPRING.
- ONCE YOU ARE READY TO STOP SHOOTING, THE TRAP MUST BE RELIEVED OF TENSION WHILE STORING, OTHERWISE THE UNIT IS ALWAYS ARMED AND UNDER PRESSURE. TO AVOID ACCIDENTAL DISCHARGE, SPRING TENSION MUST BE RELIEVED BY LOOSENING THE KNOB AND REMOVING THE SPRING. ONCE YOU ARE READY TO SHOOT AGAIN, YOU MUST REPEAT STEP 8 AND MOVE THE ARM INTO THE 12:00 POSITION AND REATTACH SPRING AND SPRING HANDLE IN ORDER TO KEEP THE TRAP IN TIME.
- ALWAYS STORE TRAP IN A DRY AREA, KEEP LUBRICATED AND FREE OF DEBRIS

TROUBLESHOOTING

NOT DROPPING CLAYS IN PROPER SEQUENCE:

YOUR TRAP IS MOST LIKELY OUT OF TIME. YOU CAN ADJUST TIMING IN THE FIELD BY ADJUSTING THE LIMIT SWITCH WITH AN ALLEN WRENCH. IF LIMIT SWITCH ADJUSTMENT ARE NEEDED, YOU MUST TURN THE MACHINE OFF, DISCONNECT TRAP FROM THE BATTERY AND RELIEVE TENSION, THEN REMOVE THE MAIN SPRING. IF THE ARM IS STOPPING TOO EARLY, MOVE THE LIMIT SWITCH SLIGHTLY TO THE RIGHT. IF THE ARM IS STOPPING TOO LATE, MOVE THE LIMIT SWITCH TO THE LEFT. YOU MIGHT HAVE TO MAKE A FEW ADJUSTMENTS BEFORE GETTING IT RIGHT. YOU CAN CHECK TIMING BY ROTATING THE ARM AND CHECKING ITS POSITION WHEN THE CLAY IS DROPPED IN RELATION TO WHEN THE LIMIT SWITCH IS ACTIVATED. ONCE TIMING HAS BEEN CORRECTED, PLEASE REPEAT STEPS 8 THROUGH 10 TO BEGIN SHOOTING.

- PLEASE CHECK THAT ALL WIRING CONNECTIONS ARE SECURE
- MAKE SURE BATTERY IS FULLY CHARGED
- IF YOU ARE UNABLE TO MAKE CORRECTIONS IN THE FIELD, PLEASE CALL 866-SHOT-DOC

IF UNIT IS NOT OPERATING PROPERLY, PLEASE CONTACT 866-SHOT-DOC FOR ASSISTANCE.

DO NOT RETURN TO STORE

DO-ALL OUTDOORS, LLC. PRIDES ITSELF ON ITS CUSTOMER SERVICE. PLEASE CONTACT US IF YOU HAVE ANY ISSUES WITH OUR PRODUCT.

WARNING: PLEASE READ BEFORE USE

SAFETY WARNINGS

- **OPERATOR MUST ALWAYS STAND BEHIND UNIT WHILE OPERATING TRAP, MAKING ADJUSTMENTS OR WHILE THE TRAP IS UNDER PRESSURE. NEVER ATTEMPT TO MAKE ADJUSTMENTS WHILE UNIT IS ARMED, UNDER SPRING TENSION OR CONNECTED TO THE BATTERY. THE SHOOTER MUST ALWAYS STAND TO THE LEFT OF THE TRAP AT A MINIMUM DISTANCE OF 30 FEET**
- ALWAYS WEAR PROPER EAR AND EYE PROTECTION.
- INSTALL ORANGE SAFETY RING BEFORE USE. THE SAFETY RING IS A VISUAL INDICATOR OF THE THROWING ARM'S PATH. NEVER PENETRATE THIS AREA WITH ANY PART OF YOUR BODY WHILE OPERATING THE UNIT.
- NEVER ATTEMPT TO MAKE ADJUSTMENTS TO THE UNIT WHILE THE UNIT IS COCKED, HOOKED UP TO THE BATTERY OR UNDER SPRING PRESSURE. ALWAYS REMOVE SPRING BEFORE MAKING ADJUSTMENTS OR REPAIRS.
- BE SURE THE UNIT IS IN GOOD OPERATING CONDITION BEFORE USE.

DO-ALL TRAPS, LLC DBA DO ALL OUTDOORS, LLC DOES NOT ACCEPT ANY RESPONSIBILITY FOR DAMAGES AND/OR INJURY SUSTAINED FROM THE USE OR MISUSE OF THIS PRODUCT.

Thank you for your business!

Customer Service: 866-SHOT-DOC
Email: customerservice@doalloutdoors.com

www.doalloutdoors.com

